

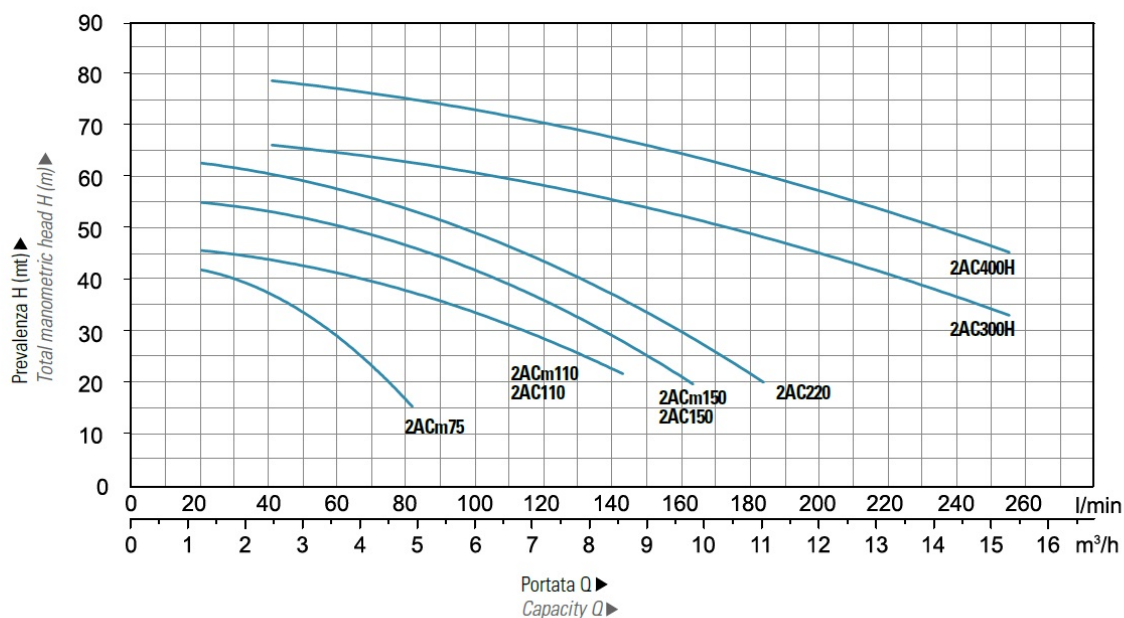

DIAGRAMMA PRESTAZIONI | HYDRAULIC PERFORMANCE CURVE



DESCRIZIONE COMPONENTI | MATERIALS TABLE

Pos. Pos.	Part. Part.	Materiale Material
1	Tappo di scarico Drain plug	Ottone HPB59-1 Brass
2	Corpo pompa Pump body	Ghisa HT200
3	Guarnizione Gasket	NBR
4	Girante Impeller	AISI 304 / Ottone Brass
5	Inserto Bracket cover	Ghisa HT200
6	Tenuta meccanica Mechanical seal	Grafite/Ceramica Carbon/Ceramic
7	Supporto motore Support	Ghisa HT200
8	Anello corteco Oil seal	
9	Cuscinetto Bearing	
10	Albero motore Rotor	
11	Cassa motore con statore avvolto Stator	
12	Coperchio motore Rear cover	Ghisa HT200
13	Ventola Fan	Tecnopolimero PP
14	Copriventola Fan cover	Tecnopolimero PP
15	Morsettiera Terminal board	Plastica PC Plastic
16	Condensatore Capacitor	
17	Copri morsettiera Capacitor box	ABS

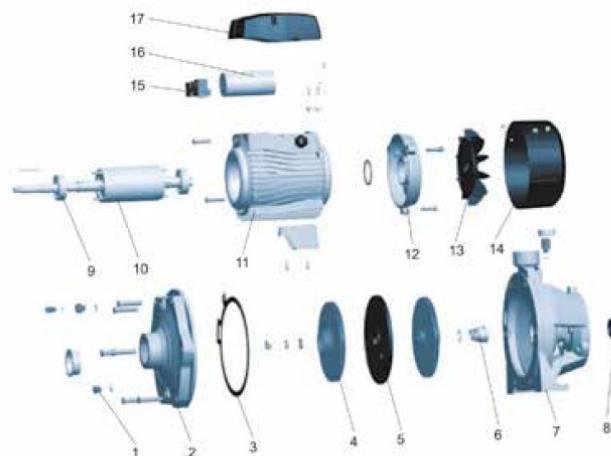

DIMENSIONI IMBALLO | PACKAGE INFORMATION

Modello Model	GW (Kg)	L (mm)	W (mm)	H (mm)
2ACm75	16.8	385	215	270
2AC/2ACm110	21	430	235	275
2AC/2ACm150	27.5	445	255	300
2AC220	27.5	445	255	300
2AC300H	51.5	542	330	346
2AC400H	52.4	542	330	346

